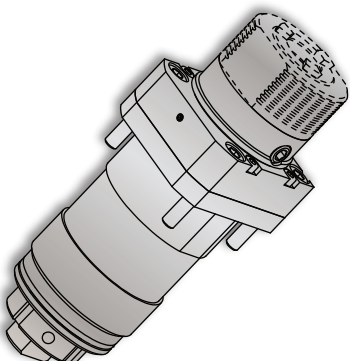
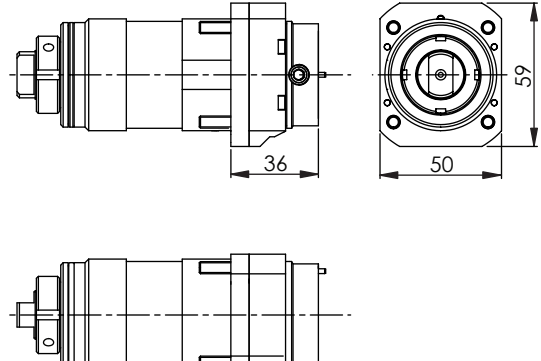
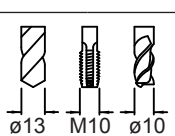

TSUGAMI

Radial Drilling and Milling Unit / Radial-Bohr-Fräseinheit
 Motorizzato Radiale di Foratura e Fresatura / Unité de Perçage et de Fraisage Radiale
 ラジアルドリルおよびミーリングユニット

Lathe Linear Unit • LLU 25-1 R • Main Spindle											
Machine Types	B0325V-III		B0326-II/III		B0385	B0385-II	B0385C	B0385L	B0386C	B0386-III	BW329Z
	HS20	HS26	HS32	SS20	SS26	SS32	S205-II	S206-II			
   <p>Compatible QC Cartridges (not incl.)</p> <ul style="list-style-type: none"> • ERAX 11 → 14420002090 • ERAX 16 → 14420002080 • ERAX 20 → 14420002070 											
#					$n_1 : n_2$	i	$n_2 \text{ max}$	$T_2 \text{ max}$			#
14101004110	QC ø24		0 bar		1:1		8'000 min ⁻¹	25 Nm			-

Notes / Notizen / Note / Notes / ㄨ ㄜ

Please check the machine strokes and the neighbor stations on potential overlaps - Bitte die Verfahrswege und die Nachbarstationen auf mögliche Überschneidungen überprüfen
 Si prega di verificare i percorsi e le stazioni adiacenti di potenziali sovrapposizioni - Vérifier les courses et qu'il n'y a pas de collisions possibles avec les stations voisines
 常に機械のストロークと、隣接するステーションにオーバーラップが無いが確認してください。
 Design data and dimensions subject to change - Konstruktions- und Massänderungen vorbehalten
 Cambiamento della costruzione e delle misure riservato - Droit de modification de structure et de cotes réservées
 設計仕様および寸法は通知することなく変更されます

